

10201-30999 ON DRG. NO.

12.5 ALL OVER UNLESS OTHERWISE STATED

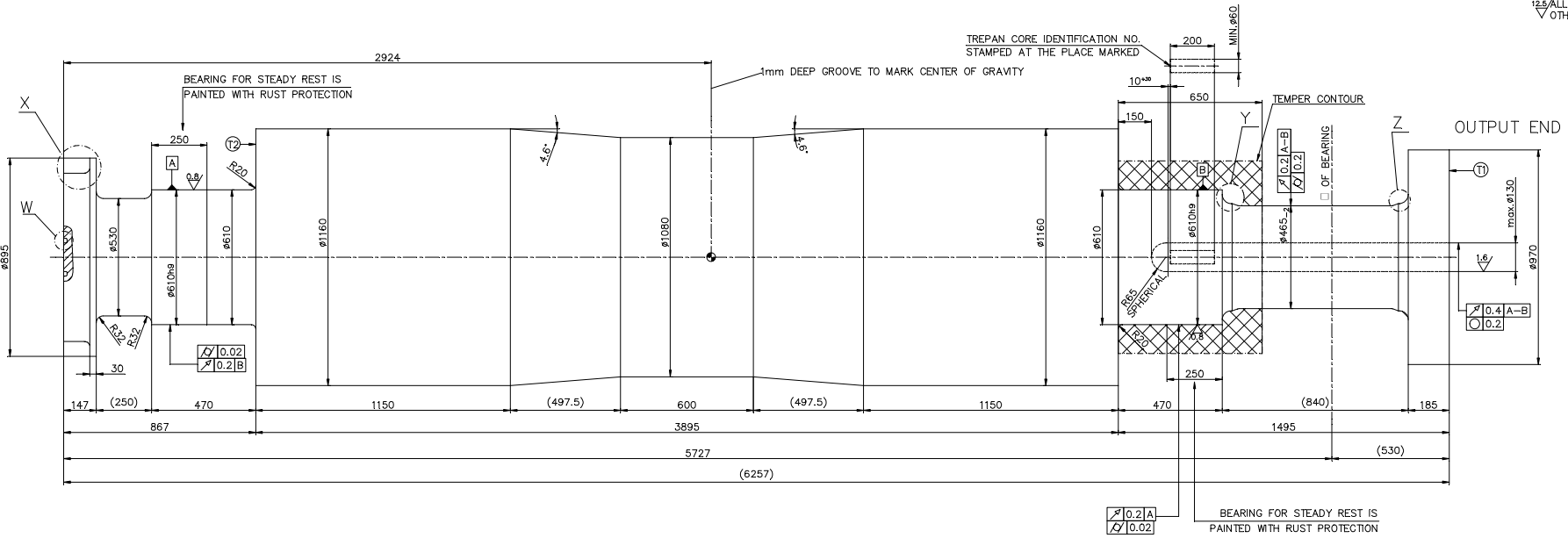

TECHNICAL REQUIREMENTS:-

- FORGING SHALL BE SUPPLIED IN ROUGH MACHINED CONDITION AS PER SPEC. NO. HW19468
- PERMISSIBLE TOLERANCES :-
ON INSIDE DIMENSION: -2.
ON OUTSIDE DIMENSION: +2.
- BRACKETED DIMENSION ARE FOR REFERENCE ONLY.
- AT THE PLACE MARKED (T) AND (T2) SUPPLIER SHALL LOCATE THE TANGENTIAL TEST SAMPLE FOR MECHANICAL TESTING. PART OF THE TEST SAMPLE (≈ 40mm) SHALL BE LEFT INTEGRAL WITH THE SHAFT FOR BHEL.
- AXIAL CORE SHALL BE TREPANED AFTER SATISFACTORY TESTING OF (T) , (T2) AND ULTRASONIC TEST. TESTING OF AXIAL CORE IS TO BE DONE AS PER SPECIFICATION AA0850155. BALANCE OF AXIAL CORE DULY MARKED WITH IDENTIFICATION NUMBER SHALL BE DENT TO BHEL ALONG WITH ROTOR.
- AFTER SATISFACTORY TESTING OF AXIAL CORE THE ROTOR PORTION SHOWN AS ~~XXXXXX~~ IS TO BE MACHINED OFF.
- THE IDENTIFICATION NUMBER MUST BE STAMPED AT THE PLACE MARKED WITH IN AND SUITABLY PAINTED WITH RUST PREVENTIVE.

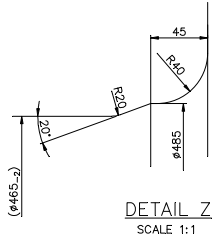
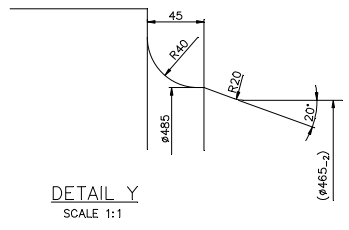
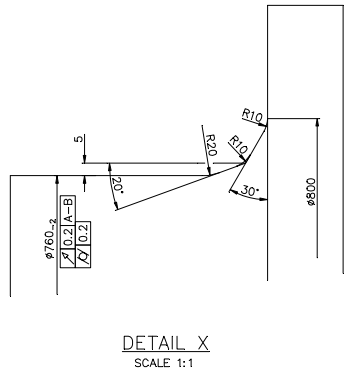
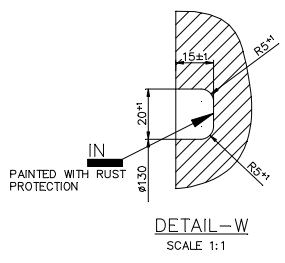

WEIGHT:	
THEORETICAL	MAXIMUM
36353KG	37800KG

FORGING FOR I.P. SHAFT		1-10201-30999	W95310201262	36353	00
VAR 00	REMARKS	ITEM No.	DESCRIPTION	DRAWING No.	
59	64	65	75	25	27
28	28	28	28	28	28
GRADE OF UNTOLDIM		STEAM TURBINE			
M/CC.-G/M/F AA0230208		OR NAME OF CUSTOMER/PROJECT			
WELDING-R/B/G/P AA0621104		BHARAT HEAVY ELECTRICALS LTD.			
GAS CUTTING-T3'AA0621101		RANIPUR, HARDWAR			
REV	DATE	ALTERED	REV	DATE	ALTERED
01	06.06.23	RAJ.PAL sd/-	01	03.01.17	RAJ.PAL sd/-
		CHEKED/SUBODH sd/-			CHEKED/SUBODH sd/-
TECH.REQ.T. NO.5 MODIFIED		DEPT MTE		SCALE	
C/A. NO. MTE-23-F0021		CODE4300		1:10	
		WEIGHT (KG)		REF. TO ASSY. DRG.	
		36353		-	
		TITLE: FORGING FOR		DRAWING NO.	
		I.P. SHAFT (ROUGH MACHINED)		1-10201-30999	
		CARD CODE		SHEET No. 01	
				No. OF SHEETS 01	

INVENTORY NO. STOK AND DATE USE AS PER APPROVAL BY THE CUSTOMER. THE INFORMATION ON THIS DOCUMENT IS THE PROPERTY OF BHARAT HEAVY ELECTRICALS LIMITED. IT MUST NOT BE USED DIRECTLY OR INDIRECTLY IN ANY WAY DETRIMENTAL TO THE INTEREST OF THE COMPANY.